

# DRYCOOL SPLIT SYSTEM

Reduce humidity, save energy with  
Munters DryCool Split System

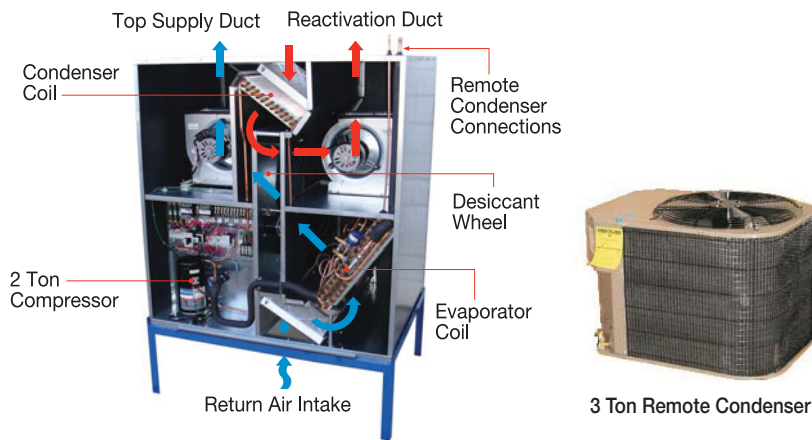

## Product Description

Munters DryCool Split System is equipped with five tons of cooling and a desiccant wheel to control humidity and temperature independently.

It offers two stages of cooling. First the unit activates the two ton internal compressor, then the second stage brings on a three ton remote condenser.

This unique combination of compressor staging and the utilization of Munters' desiccant dehumidification wheel provides continuous humidity control while consuming less energy than conventional HVAC systems.

Conventional 5 ton systems consume more energy because they use all five compressor tons to control climate, even when there is no need for cooling.

Munters DryCool Split System treats 2,200 total cfm of air (up to 500 cfm OA), offers easy installation and has a compact design. The three ton remote condenser is installed outdoors either on the roof or next to your building.

Unit can be applied anywhere a standard 5 ton is applicable and is suitable for new and retrofit applications.

## PRODUCT INFORMATION

# DRYCOOL SPLIT

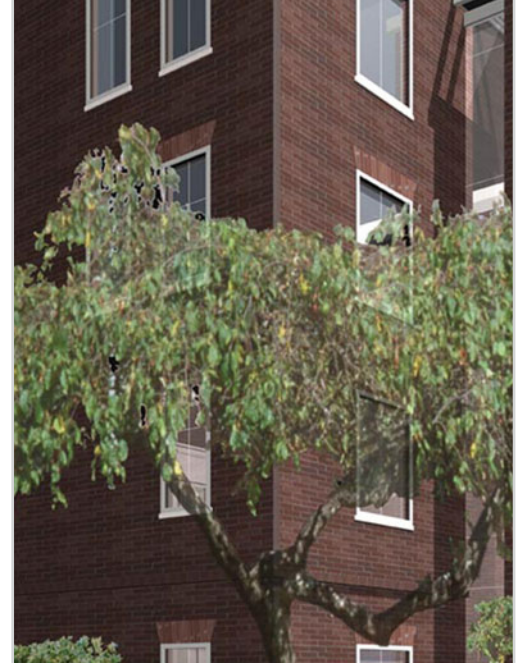

## Benefits

- Consistent Humidity & Temperature Control
- Easy to Install & Operate
- Lower Utility Bills
- Compact Design

## DryCool Split System Schedule

Air Handler Dimensions (HxWxD)	69"H x 54"W x 46"D	
Air Handler Weight (+/- 10%)	450 lbs	
Condensing unit Dimensions (HxWxD)	27"H x 37"W x 27"D	
Condensing unit Weight	210 lbs	
<b>Supply Fan</b>		
Type	Direct-Drive Forward Curve	
HP	1 1/2	
CFM	2,200	
ESP ("WG)	0.5" WC	
<b>Reactivation Fan</b>		
Type	Direct-Drive Forward Curve	
HP	3/4	
CFM	1,540	
ESP ("WG)	0.5" WC	
<b>Compressors</b>		
Air handler tons	2	
Remote cond unit tons	3	
Total tons cooling	5	
Refrigerant	R-22	
<b>After Heat</b>		
Type	10 kW electric	
<b>Filter</b>		
Type	2" Pleated Disposable	
Number and size	4 ea 16 x 20 x 2	
<b>Air Handler Electrical</b>		
Power	208 / 3 / 60	460 / 3 / 60
Supply Motor	5.8	2.9
Reactivation Motor	4.0	2.0
Compressor A	7.1	3.5
Control Transformer	0.6	0.3
Electric Heater	27.8	12.6
Crankcase Heaters	0.3	0.2
FLA	34.5	16.0
MCA	43.2	19.9
MOP	45	20
<b>Condensing Unit Electrical</b>		
FLA	11.7	7.8
MCA	14.3	9.6
MOP	20	15

## General Arrangement

Front Cutaway View

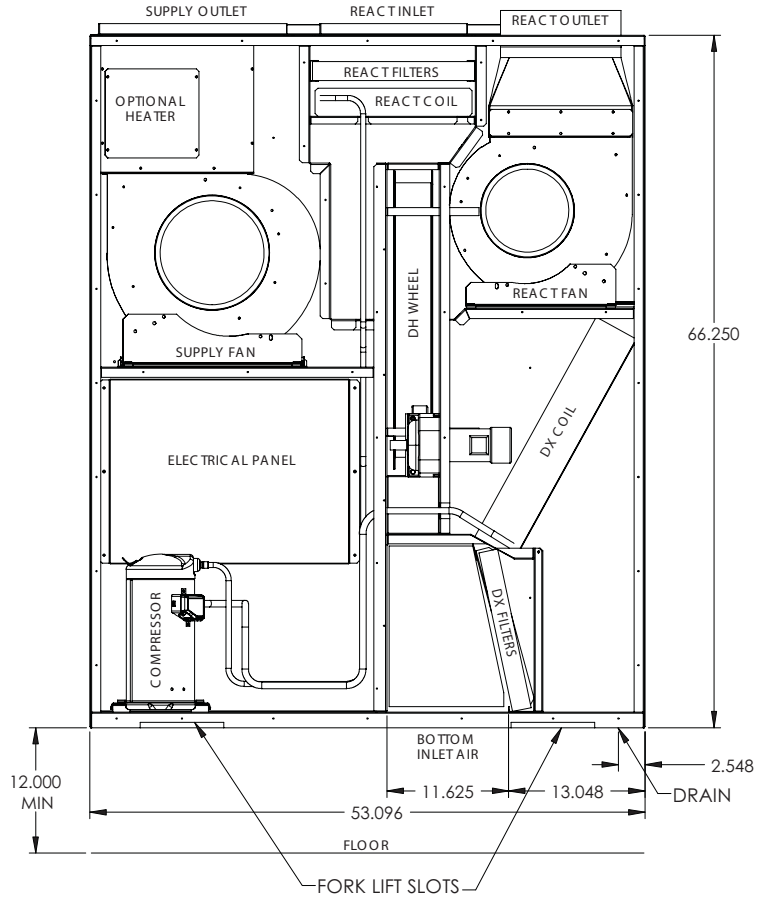

Top View

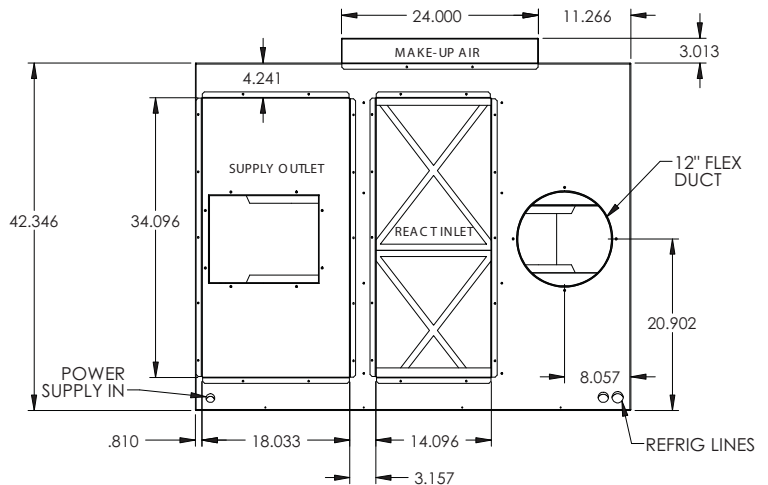

Munters Corporation  
 Protected by one or more of the following U.S. Patents.  
 5435958; 5505769; 5423934; 5500402; 6375914;  
 6557365; 6622508; 6711907; 6875299; 7047751.  
 U.S. and worldwide Patents Pending.

**Munters Corporation**  
 Tel: (800) 843-5360  
 E-mail: [dhinfo@munters.com](mailto:dhinfo@munters.com)  
[www.munters.us](http://www.munters.us)

